

max. Nachschleiflänge

bei $s_2 = 2.5 \text{ mm}$

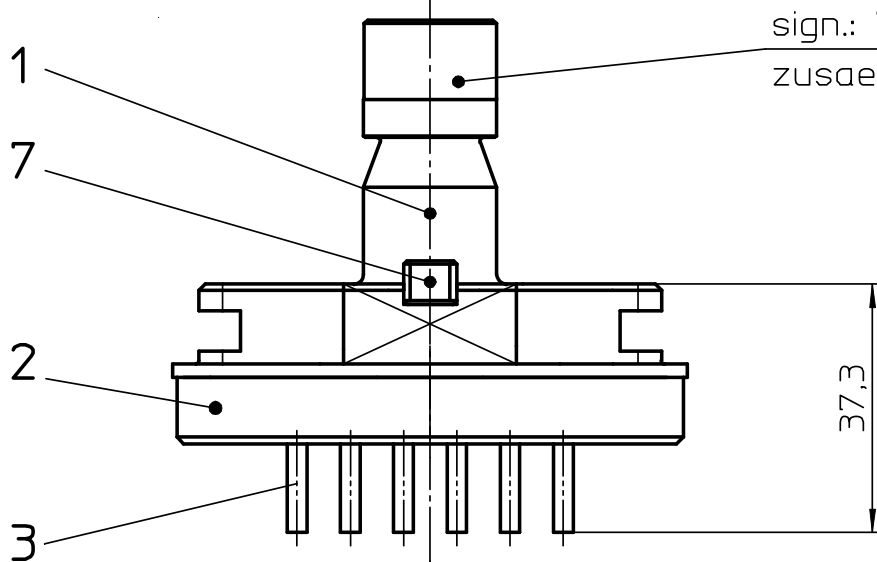

sign.: 73X121-172-S
zusätzlich sign.: T

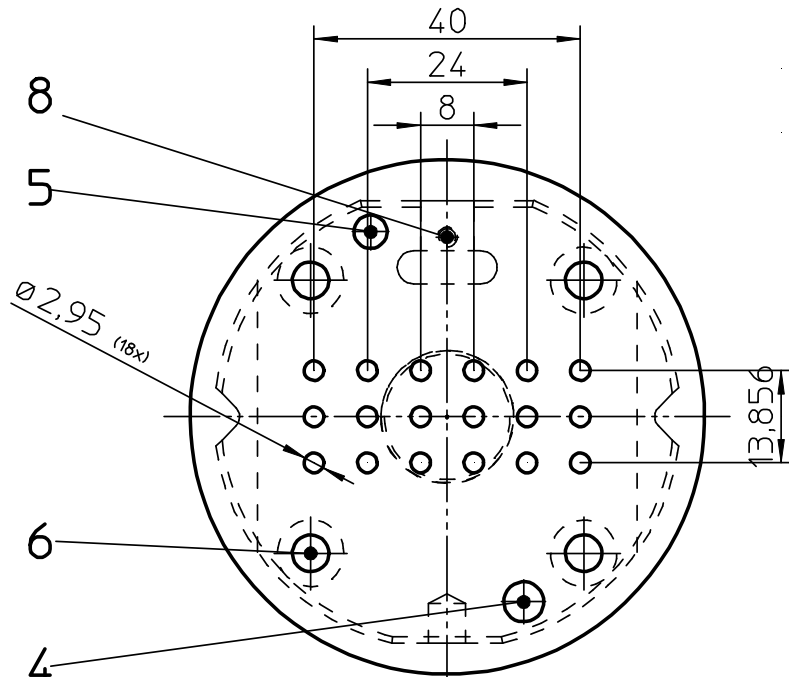

sign.: 73X121-172-A

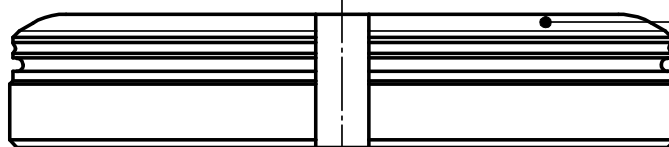

sign.: 73X121-172-M

sp=0.4